

Application:

UNY and UNF unions are installed in threaded thickwall conduit systems:

- UNY – to connect conduit to a conduit fitting, junction box or device enclosure
- UNF – to connect conduit to conduit, or to provide a means for future modification of the conduit system

UNA unions are used in conduit and fitting installations when entrance angle is between 90° and 180°.

EL elbows are installed in conduit run or in box or fitting hub:

- to change direction in threaded rigid conduit run by 90°, or when terminating at a box or fitting

Features:

UNY, UNF and UNL unions have:

- compact design which permits assembly with a minimum of clearance to other adjacent conduit and/or equipment
- strong and durable construction

UNA unions:

- have a single clamping nut on angle, making it both a union and a connector
- permit conduit joints at angles between 90° and 180°

EL elbows have a smooth interior and are both strong and compact.

Standard Materials:

- UNY, UNF unions – 1/2" to 1" – steel
- UNY, UNF unions – 1 1/4" to 6" – *Feraloy*® iron alloy
- UNL, UNA unions – *Feraloy* iron alloy
- EL elbows – *Feraloy* iron alloy or ductile iron

Standard Finishes:

- Steel – electrogalvanized with chromate treatment
- *Feraloy* iron alloy, malleable iron – electrogalvanized and aluminum acrylic paint

Options:

- Copper-free aluminum – add suffix SA to Cat. No. (not available on UNA or 5" and 6" UNY/UNF)

† See compliances for classification of each product.

Certifications and Compliances:

- NEC/CEC:
 - Class I, Division 1 & 2, Groups A,B,C,D
 - Class II, Div. 1, Groups E,F,G
 - Class II, Division 2, Groups F,G
- Class III
 - EL 1/2", 3/4", 1"
 - UNF/UNY 105, -215, -205, -305
 - UNL 105, -125, -215, -205
- Class I, Division 1 & 2, Groups B,C,D
- Class II, Division 1, Groups E,F,G
- Class II, Division 2, Groups F,G
- Class III
 - UNF/UNY406, -506, -606, -706, -806, -905, -1005
- Class I, Division 1 & 2, Groups C,D
- Class II, Division 1, Groups E,F,G
- Class II, Division 2, Groups F,G
- Class III
 - EL, UNF, UNL, UNY - all sizes

- Class I, Division 1 & 2, Group D
- Class II, Division 1, Groups E,F,G
- Class II, Division 2, Groups F,G
- Class III
 - UNA
- UL Standard: 886
- CSA Standard: C22.2 No. 30



UNL

90° Angle

Size	Cat. #
1/2 to 1/2	UNL105
3/4 female to 1/2 male	UNL125
1/2 female to 3/4 male	UNL215
3/4 to 3/4	UNL205

Dimensions

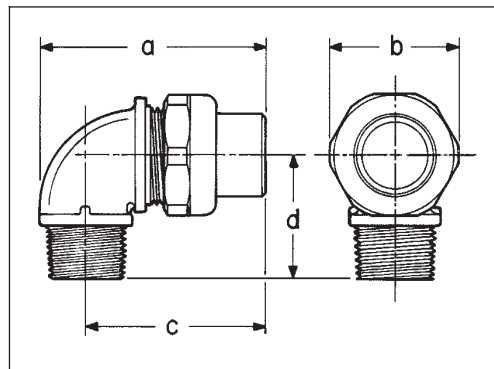

1/2" - 4"



5" - 6"

UNY Male

Size	Cat. #
1/2	UNY105
1/2 female to 3/4 male	UNY215
3/4	UNY205
1	UNY305
1 1/4	UNY405
1 1/4	UNY406
1 1/2	UNY505
1 1/2	UNY506
2	UNY605
2	UNY606
2 1/2	UNY705
2 1/2	UNY706
3	UNY805
3	UNY806
3 1/2	UNY905
4	UNY1005
5	UNY012
6	UNY014



1/2" - 4"



5" - 6"

UNF Female

Size	Cat. #
1/2	UNF105
3/4 to 1/2	UNF215
3/4	UNF205
1	UNF305
1 1/4	UNF405
1 1/4	UNF406
1 1/2	UNF505
1 1/2	UNF506
2	UNF605
2	UNF606
2 1/2	UNF705
2 1/2	UNF706
3	UNF805
3	UNF806
3 1/2	UNF905
4	UNF1005
5	UNF012
6	UNF014

Size	UNY Length	Max. Dia.	UNF Length	Max. Dia.
1/2	2 3/8	1 1/2	1 13/16	1 1/2
3/4-1/2	2 7/16	1 13/16	1 3/4	1 13/16
3/4	2 7/16	1 13/16	1 3/4	1 13/16
1	2 3/4	1 7/8	2	1 7/8
1 1/4	3 3/16	2 3/4	2 1/4	2 3/4
1 1/2	3 9/16	3 1/16	2 5/8	3 1/16
2	3 3/4	3 13/16	2 9/16	3 13/16
2 1/2	4 5/8	4 5/8	3 3/16	4 5/8
3	5	5 1/16	3 7/16	5 1/16
3 1/2	5 1/2	5 11/16	4 1/8	5 11/16
4	5 5/8	6 3/16	4 1/8	6 3/16
5	5 1/4	8 3/16	3 13/16	8 3/16
6	5 3/8	9 5/16	3 13/16	9 5/16
UNL				
Dim.	105	125	215	205
a	2 1 1/16	2 1 1/16	2 7/8	2 7/8
b	1 17/32	1 13/16	1 13/16	1 13/16
c	2 1/16	2 1/4	2 1/4	2 1/4
d	1 7/16	1 7/16	1 5/8	1 5/8