

Señalización Audio Visual

Section S

A comprehensive range of signaling products specifically designed for use in areas where harsh environmental conditions prevail and where there is a risk of explosion due to the presence of flammable atmospheres.



MEDC Series



XB16



XB15 Pipe Mount (with cast guard)

These listed strobes have been designed for use in potentially explosive atmospheres and harsh environmental conditions. The enclosures are suitable for use offshore or onshore, where a lightweight product combined with corrosion resistance is required.

The housing is manufactured from a U.V. stable, glass reinforced polyester, with the lens manufactured from a U.V. stable polycarbonate. Stainless steel screws are used, ensuring a totally corrosion-free product.

The strobes contain supervisory diode and four wire leads for fire alarm applications. This strobe is also available UL 1971 (ADA) Listed for hearing impaired applications.

Units can be painted to customer specification and supplied with identification labels.

Applications:

- Condition signaling
- Security alert
- Equipment obstruction warning
- Emergency evacuation signaling

Features and Benefits:

- Pipe mount with 1/2" NPT entry
- Corrosion resistant GRP enclosure
- XB16 580,000 peak candlepower
XB15 520,000 peak candlepower
- Polycarbonate lens, various colors available†
- 4 wire diode monitored board
- Optional relay initiate
- Optional lens guard

†UL 1971 version available with clear lens only (XB16 only).

*Conforms to UL regulated voltage.

Certifications and Compliances:

- UL Listed for USA and Canada
 - Hazardous locations for USA and Canada
Class I, Div. 2, Groups A, B, C, D*
UL 1971 compliant version available
 - Ordinary locations: Visual Signal Device
- NEMA 4X and 6, IP66 & 67
- Certified temperature
 - 67°F to +158°F
 - 55°C to +70°C

Typical Industries:

- Utility gas plants
- Wastewater treatment plants
- Mining
- Petroleum refineries
- Chemical and petrochemical
- Pulp and paper

MEDC Series

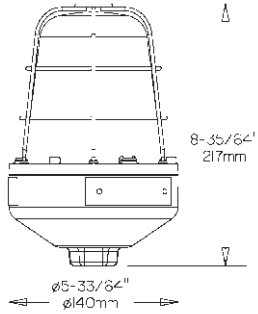
XB16 UL		10 Joule Flashing Xenon—Hazardous & Ordinary Locations	
	Certification UL Listed for:	cULus, UL 1971 compliant Class I, Div. 2, Groups A, B, C, D	
	Certified Ambient Temperature	-67°F to +158°F -55°C to +70°C	
	Ingress Protection	NEMA 4X & 6 IP66 & 67	
	Material	Corrosion-free GRP	
	Entries	Standard 1 x 1/2" NPT	
	Weight	2.2lb/1kg	
	Options	Body & lens color, lens guard, voltages 12–48V DC, 110–254V AC	
			

Certification	Voltage	Lens Color	Ordering Code	Cat. #	Standard Product Configuration
UL 1971 compliant	24V DC	Clear	29600023	XB16US02460CYNN	UL 1971 Listed for signaling devices for the hearing impaired. Suitable for fire alarm indication. 10 joule beacon, 60 flashes per minute, lens guard, pipe mounting, 1 x 3/4" NPT entry, natural black enclosure
UL, cUL Listed, Class I, Div. 2, Groups A, B, C, D	120V AC	Blue	869406	XB16UL12060BYNN	10 joules, 60 flashes per minute, 1 x 3/4" NPT entry, 240 Cd, lens guard, natural black finish
UL, cUL Listed, Class I, Div. 2, Groups A, B, C, D	120V AC	Red	869407	XB16UL12060RYNN	
UL, cUL Listed, Class I, Div. 2, Groups A, B, C, D	120V AC	Amber	869408	XB16UL12060AYNN	
UL, cUL Listed, Class I, Div. 2, Groups A, B, C, D	120V AC	Clear	29600013	XB16UL12060CYNN	10 joule beacon, 60 flashes per minute, lens guard, pipe mounting, 1 x 3/4" NPT entry, natural black enclosure
UL, cUL Listed, Class I, Div. 2, Groups A, B, C, D	120V AC	Green	29600014	XB16UL12060GYNN	
UL, cUL Listed, Class I, Div. 2, Groups A, B, C, D	120V AC	Blue	29600011	XB16UL12060BYNN	
UL, cUL Listed, Class I, Div. 2, Groups A, B, C, D	120V AC	Red	29600003	XB16UL12060RYNN	
UL, cUL Listed, Class I, Div. 2, Groups A, B, C, D	120V AC	Amber	29600004	XB16UL12060AYNN	
UL, cUL Listed, Class I, Div. 2, Groups A, B, C, D	24V DC	Green	29600016	XB16UL02460GYNN	10 joule beacon, 60 flashes per minute, lens guard, pipe mounting, 1 x 3/4" NPT entry, natural black enclosure
UL, cUL Listed, Class I, Div. 2, Groups A, B, C, D	24V DC	Blue	29600017	XB16UL02460BYNN	
UL, cUL Listed, Class I, Div. 2, Groups A, B, C, D	24V DC	Red	869410	XB16UL02460RYNN	
UL, cUL Listed, Class I, Div. 2, Groups A, B, C, D	24V DC	Amber	869411	XB16UL02460AYNN	

2S

MEDC Series

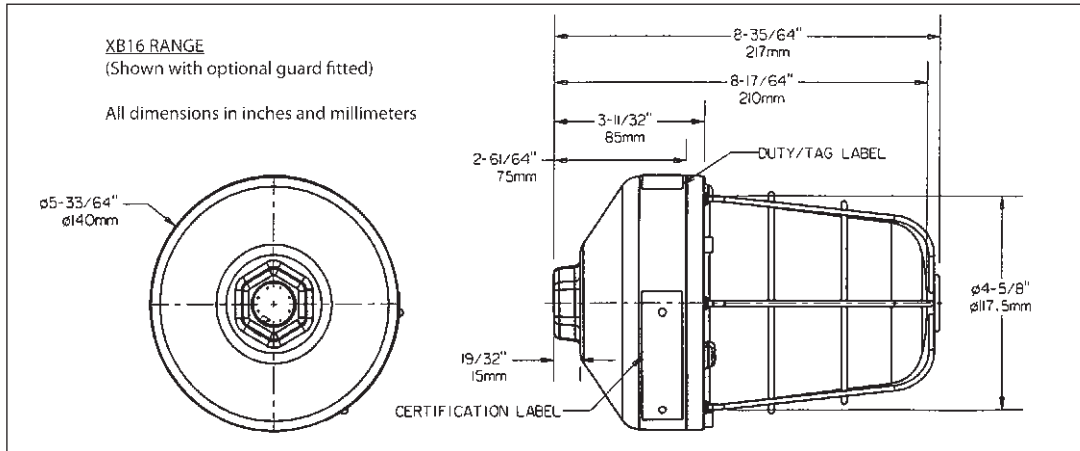

Specification—XB16UL Unit

Certification: UL Listed for USA and Canada:
 – Hazardous locations for USA and Canada
 Class I, Div. 2, Groups A, B, C, D
 UL listing No. E251185
 – Ordinary locations: Visual Signal Device: UL1638
 UL listing No. E251185
 – Hazardous locations for hearing impaired: UL1971
 UL listing No. E251185

Material: Body: Glass reinforced polyester
 Lens: U.V. stable polycarbonate
 Lens screws: stainless steel 316

Finish: Natural black or painted to customer specification

Voltage: 24, 48V DC
 110, 120, 230, 240, 254V AC
 Conforms to UL regulated voltage output (12V DC, 24V DC, 120V AC, 240V AC)

Certified Temperature: –67°F to +158°F (–55°C to +70°C)

Tube Energy: 10 joules

Tube Life: > 1 × 10⁶ flashes

Weight: 2.2lb/1.0kg

Ingress Protection: NEMA 4X & 6, IP66 & IP67

Entries: Standard 1 × 1/2" NPT pipe mount

Terminals: 8 × 14AWG

Labels: Tag/Duty label option

Electrical Ratings:

For Hazardous Locations and Ordinary Locations (UL1638) Units

Voltage	DC		AC				
	24	48	110	120	230	240	254
Current (A) at 60 fpm	0.89	0.30	0.38	0.38	0.22	0.22	0.18
Current (A) at 80 fpm	0.89	0.30	0.38	0.38	0.22	0.22	0.18
Current (A) at 120 fpm	0.89	0.30	0.38	0.38	0.22	0.22	0.18

Effective intensity (Cd): 240 at 80 f.p.m.
 Peak candlepower: 580,000 (Peak candlepower is the maximum light intensity generated by a flashing light during its light pulse)

For UL1971 Units Only

Voltage	DC		AC				
	24	48	110	120	230	240	254
Current (A) at 60 fpm	1.22	1.52	0.38	0.38	0.78	0.78	0.18
Current (A) at 80 fpm	1.22	1.52	0.38	0.38	0.78	0.78	0.18
Current (A) at 120 fpm	1.22	1.52	0.38	0.38	0.78	0.78	0.18

Effective intensity (Cd): 240 at 80 fpm.
 Peak candlepower: 580,000 (Peak candlepower is the maximum light intensity generated by a flashing light during its light pulse)
 On UL1971 units, max. current rating is based on in-rush current. This is why the current ratings are not proportional as with other beacons/strobes.
 UL 1971 On-axis output: 15 Cd.

Note: 24V DC units are certified for use in regulated 24V DC supplies (16–33V AC).
 110/120V DC units are certified for use on regulated 120V AC supplies (96–132V AC).
 230/240V DC units are certified for use on regulated 240V AC supplies (192–264V AC).

Multiplying factor for colored lenses:

Red	Blue	Amber	Green	Yellow
0.15	0.12	0.51	0.49	0.86

Ordering Requirements

The following code is designed to help in the selection of the correct unit. Build up the reference number by inserting the code for each component into the appropriate box.

Model	Certification	Voltage	Flashrate	Lens Color	Guard	Options	Unit Finish
XB16	UL		60			N	N

Certification	Code	Voltage	Code
UL	UL	12V DC	012
		24V DC	024
		110V AC	110
		120V AC	120
		240V AC	240

Lens Flashrate	Code
80	80 fpm
120	120 fpm

Color	Code
Red	R
Blue	B
Green	G
Amber	A
Yellow	Y
Clear	C

Guard	Code
Yes	Y
None	N

The **Hazard•Gard EXS and EXDS Series** Explosionproof Strobe Lights are designed for installation indoors and outdoors in locations which are hazardous due to the presence of flammable vapors or gases, ignitable dusts or ignitable fibers and flyings. The units are UL Listed for Type 3R and 4X installations. The 120V and 24V DC models are Marine Rated. The strobes are available for pendant, wall, stanchion and ceiling mounts, and come in six different globe colors.

The **EXDS Series** is diode polarized for use in electrically supervised circuits. Electrically supervised circuits are typically used in life-safety or security applications.

Under normal operation the diode is reversed biased, meaning it blocks voltage from being applied to the strobe and prevents it from lighting. When an initiating device such as a smoke detector is activated, the diode's polarity is reversed through a circuit panel. The diode becomes forward biased, allowing voltage to the device and activating the strobe.

Applications:

- Condition signaling
- Equipment obstruction warning
- Security alert
- Emergency evacuation signaling
- In areas where audible signals cannot be heard

Typical Industries:

- Utility gas plants
- Petroleum refineries
- Wastewater treatment plants
- Chemical and petrochemical
- Mining
- Pulp and paper

Features and Benefits:

- Strong strobe signal that produces 65 flashes per minute
- Compact design will not obstruct in low ceiling or small areas, ceiling mount is only 13 $\frac{3}{4}$ "-inch long
- Quick connect—strobe fixture threads onto mounting module for easy installation
- Factory sealed—no external seals required
- Available in pendant, wall, stanchion and ceiling mount
- Available in six different globe colors—clear, red, blue, amber, green and magenta
- Silicone gasket seals out dirt and moisture

Certifications and Compliances:

- Class I, Division 1, Groups C, D
- Class I, Zones 1 and 2, Group IIB
- Class II, Division 1, Groups E, F, G
- Class III
- UL and cUL 1638, UL 1203 and UL 844 Listed
- 1598A Marine Listed (120V AC and 24V DC only)
- cUL Listed C22.2 No. 205
- NEMA 4X watertight, IP66



Materials and Finishes:

- Body, mounting modules and guard—Copper-free aluminum
- Globe—Heat and impact-resistant glass
- Gaskets—Silicone
- External hardware—Stainless steel
- Internal components—Solid-state electronics in a moisture-resistant and heat-dissipating epoxy
- Epoxy powder coated for corrosion resistance

Ratings:

- 120V AC (EXS), 12–48V DC (EXSNM) and 24V DC nominal, voltage operating range is 16–33V DC (EXDS)
- Operating Current: 0.10 amps at 120V AC
1.2–3.8 amps at 12–48V DC
0.8 amps at 24V DC
- Peak Candlepower: 800,000

Hub Size:

- $\frac{3}{4}$ -inch NPT pendant, ceiling and wall mount
- 1 $\frac{1}{4}$ -inch NPT stanchion mount

Explosionproof Strobe Lights

HAZARD•GARD™ Series

Cl. I, Div. 1, Groups C, D
 Cl. I, Zone 1 and 2, Group IIB
 Cl. II, Div. 1, Groups E, F, G
 Class III

UL and cUL Listed
 NEMA 4X; IP66

2S

Ordering Information:

Step 1 - Order Strobe Type

Cat. #	Voltage	Lens Color	NEMA Rating
Explosionproof Strobes			
EXS301A/120	120V AC	Amber	3R 4X, Marine
EXS301B/120	120V AC	Blue	3R 4X, Marine
EXS301C/120	120V AC	Clear	3R 4X, Marine
EXS301G/120	120V AC	Green	3R 4X, Marine
EXS301M/120	120V AC	Magenta	3R 4X, Marine
EXS301R/120	120V AC	Red	3R 4X, Marine
EXSNM301A/12 48	12-48V DC	Amber	3R 4X
EXSNM301B/12 48	12-48V DC	Blue	3R 4X
EXSNM301C/12 48	12-48V DC	Clear	3R 4X
EXSNM301G/12 48	12-48V DC	Green	3R 4X
EXSNM301M/12 48	12-48V DC	Magenta	3R 4X
EXSNM301R/12 48	12-48V DC	Red	3R 4X
Diode Polarized Explosionproof Strobes			
EXDS301A/24	24V DC	Amber	3R 4X, Marine
EXDS301B/24	24V DC	Blue	3R 4X, Marine
EXDS301C/24	24V DC	Clear	3R 4X, Marine
EXDS301G/24	24V DC	Green	3R 4X, Marine
EXDS301M/24	24V DC	Magenta	3R 4X, Marine
EXDS301R/24	24V DC	Red	3R 4X, Marine

Step 2 - Order Mounting Module

Cat. #	Hub Size	Mounting Style
EVMP2	3/4"	Pendant
EV22 and EV87	3/4"	Wall
EV22	3/4"	Ceiling
EVMJ4	1 1/4"	Stanchion

Temperature Performance Data:

	Ambient Max. Temp.	Supply Wire	Class I, Div. 1, 2, Groups C, D, Class I, Zone 1, Group II B	Class II, Class III, Div. 1, Groups E, F, G	Class II, Class III, Div. 2, Groups F, G
EXFASC Series Fire Alarm Voltage 24V DC Regulated Full Wave Rectified (Operating Range 16-33V DC) (Marine Listed)	40°C	75°C	T6 (85°C)	T4A (120°C)	T4A (120°C)
	55°C	90°C	T5 (100°C)	T4 (135°C)	T4 (135°C)
EXS Series Strobe Light Voltage 120V AC (Marine Listed)	40°C	75°C	T6 (85°C)	T4A (120°C)	T4A (120°C)
	55°C	90°C	T6 (85°C)	T4 (135°C)	T4 (135°C)
	65°C	105°C	T6 (85°C)	T4 (135°C)	T4 (135°C)
EXSNM Series Strobe Light Voltage 12-48V DC (Not Marine Listed)	40°C	75°C	T6 (85°C)	T4A (120°C)	T4A (120°C)
	55°C	90°C	T6 (85°C)	T4 (135°C)	T4 (135°C)
	65°C	105°C	T6 (85°C)	T4 (135°C)	T4 (135°C)
EXDS Series Strobe 40°C Light-Diode Polarized Voltage 24V DC (Marine Listed)	40°C	75°C	T6 (85°C)	T4A (120°C)	T4A (120°C)
	55°C	90°C	T5 (100°C)	T4 (135°C)	T4 (135°C)

2S

2S Explosionproof Strobe Lights HAZARD•GARD™ Series

Cl. I, Div. 1, Groups C, D
Cl. I, Zone 1 and 2, Group IIB
Cl. II, Div. 1, Groups E, F, G
Class III

UL and cUL Listed
NEMA 4X; IP66

Dimensions In Inches:

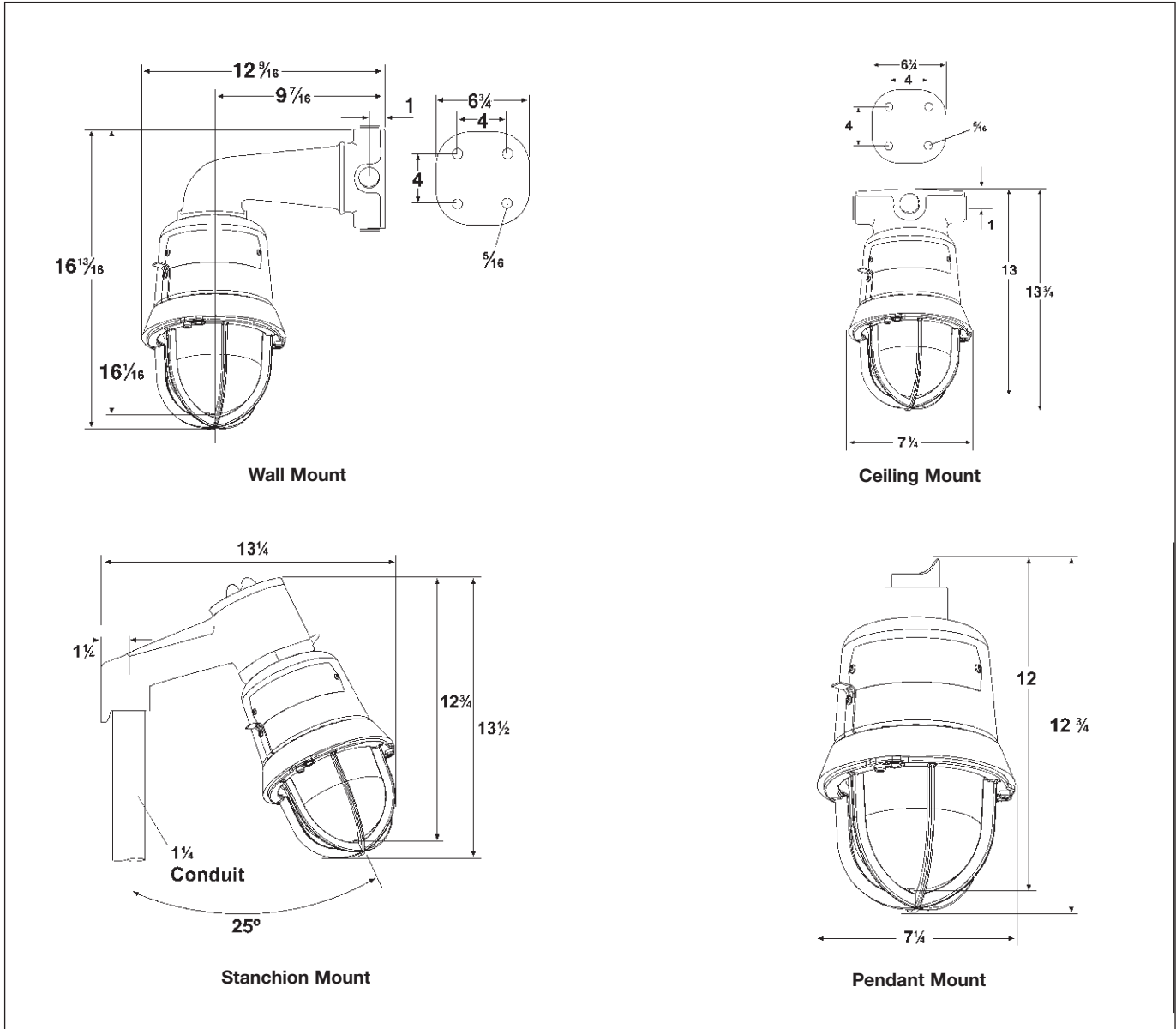

2S

Net Luminaire Weights:

Type	lbs.
Luminaire Housing with Guard	11.0

Type	lbs.
Add mounting modules:	
Pendant	1.0
Ceiling	1.0
Wall	4.5
Stanchion	2.5

Explosionproof Rotating Beacons

HAZARD•GARD™ Series

Cl. I, Div. 1, Groups C, D
Cl. I, Zone 1 and 2, Group IIB
Cl. II, Div. 1, Groups E, F, G
Class III

UL and cUL Listed
NEMA 4X; IP66

2S

Cooper Crouse-Hinds **Hazard•Gard EXR Series Explosionproof Rotating Beacons** are designed for installation in hazardous locations, such as manufacturing plants, heavy industrial facilities, refineries, chemical, petrochemical, pharmaceutical and off-shore drilling platforms.

The units are UL Listed for Type 3R, 4X and marine installations. The rotating beacons are available for pendant, wall, stanchion and ceiling mounts, and come in six different globe colors.

The EXDR Series Explosionproof Rotating Beacon is diode polarized for use in standard 24–28V DC electrical circuits or in electrically supervised circuits. Electrically supervised circuits are typically used in life-safety or security applications.

Under normal operation in an electrically supervised circuit, the diode is reversed biased, meaning it blocks voltage from being applied to the rotating beacon and prevents it from lighting. When a warning detecting device is activated, the diode's polarity is reversed through a circuit panel. The diode becomes forward biased, allowing voltage to the device and activating the rotating beacon.

Applications:

- Security alert
- Equipment obstruction warning
- Obstacle warning
- Status indication of a process
- Areas under construction
- Supplement audible signaling or off limits

Typical Industries:

- Utility gas plants
- Pharmaceutical plants
- Wastewater treatment plants
- Refineries
- Chemical plants
- Mining

Features and Benefits:

- Powerful halogen rotating beacon emits bright light to provide critical visual warning
- Available in pendant, wall, stanchion and ceiling mount
- Available in six different globe colors—amber, blue, clear, green, magenta and red
- Beacon produces 75 rotations per minute
- Factory sealed—no external seals required
- Quick connect—strobe fixture threads onto mounting module for easy installation

Certifications and Compliances:

- Class I, Division 1, Groups C, D
- Class II, Division 1, Groups E, F, G
- Class I, Zones 1 & 2, Group IIB
- Class III
- UL and cUL 1638, UL 1203 and UL 844 Listed
- 1598A Marine Listed
- NEMA 4X watertight, IP66



Materials and Finishes:

- Body, mounting modules and guard—Copper-free aluminum
- Globe—Heat and impact-resistant glass
- Gaskets—Silicone
- External hardware—Stainless steel
- Internal components—Solid-state electronics in a moisture-resistant and heat-dissipating epoxy
- Epoxy powder coated for corrosion resistance

Ratings:

- 120V AC (EXR) and 24–28V DC (EXDR)
- Operating Current: 0.382 amps at 120V AC
0.8 amps at 24–28V DC
- Peak Candlepower: 3328 (EXR)
2838 (EXDR)

Hub Size:

- 3/4-inch NPT pendant, ceiling and wall mount
- 1 1/4-inch NPT stanchion mount

2S Explosionproof Rotating Beacons HAZARD•GARD™ Series

Cl. I, Div. 1, Groups C, D
Cl. I, Zone 1 and 2, Group IIB
Cl. II, Div. 1, Groups E, F, G
Class III

UL and cUL Listed
NEMA 4X; IP66

Ordering Information:

Step 1 - Order Rotating Beacon Type

Cat. #	Voltage	Lens Color	NEMA Rating
Explosionproof Rotating Beacons			
EXR301A/120	120V AC	Amber	3R, 4X, Marine
EXR301B/120	120V AC	Blue	3R, 4X, Marine
EXR301C/120	120V AC	Clear	3R, 4X, Marine
EXR301G/120	120V AC	Green	3R, 4X, Marine
EXR301M/120	120V AC	Magenta	3R, 4X, Marine
EXR301R/120	120V AC	Red	3R, 4X, Marine
Diode Polarized Explosionproof Rotating Beacons			
EXDR301A/24 28	24–28V DC	Amber	3R, 4X, Marine
EXDR301B/24 28	24–28V DC	Blue	3R, 4X, Marine
EXDR301C/24 28	24–28V DC	Clear	3R, 4X, Marine
EXDR301G/24 28	24–28V DC	Green	3R, 4X, Marine
EXDR301M/24 28	24–28V DC	Magenta	3R, 4X, Marine
EXDR301R/24 28	24–28V DC	Red	3R, 4X, Marine

Step 2 - Order Mounting Module

Cat. #	Hub Size	Mounting Style
EVMP2	3/4"	Pendant
EV22 & EV87	3/4"	Wall
EV22	3/4"	Ceiling
EVMJ4	1 1/4"	Stanchion

Temperature Performance Data:

Description	Ambient Max. Temp.	Supply Wire	Class I, Div. 1, 2, Groups C, D Class I, Zone 1, Group IIB	Class II, Class III, Div. 1, Groups E, F, G	Class II, Class III, Div. 2, Groups F, G
EXR Series Rotating Beacon Voltage 120V AC	40°C	75°C	T6 (85°C)	T4A (120°C)	T4A (120°C)
	55°C	90°C	T5 (100°C)	T4 (135°C)	T4 (135°C)
	65°C	105°C	T5 (100°C)	T4 (135°C)	T4 (135°C)
EXR Series Rotating Beacon—Diode Polarized Voltage 24–28V DC	40°C	75°C	T6 (85°C)	T4A (120°C)	T4A (120°C)
	55°C	90°C	T6 (85°C)	T4 (135°C)	T4 (135°C)
	65°C	105°C	T6 (85°C)	T4 (135°C)	T4 (135°C)

Explosionproof Rotating Beacons HAZARD•GARD™ Series

Cl. I, Div. 1, Groups C, D
Cl. I, Zone 1 and 2, Group IIB
Cl. II, Div. 1, Groups E, F, G
Class III

UL and cUL Listed
NEMA 4X; IP66

2S

Dimensions In Inches:

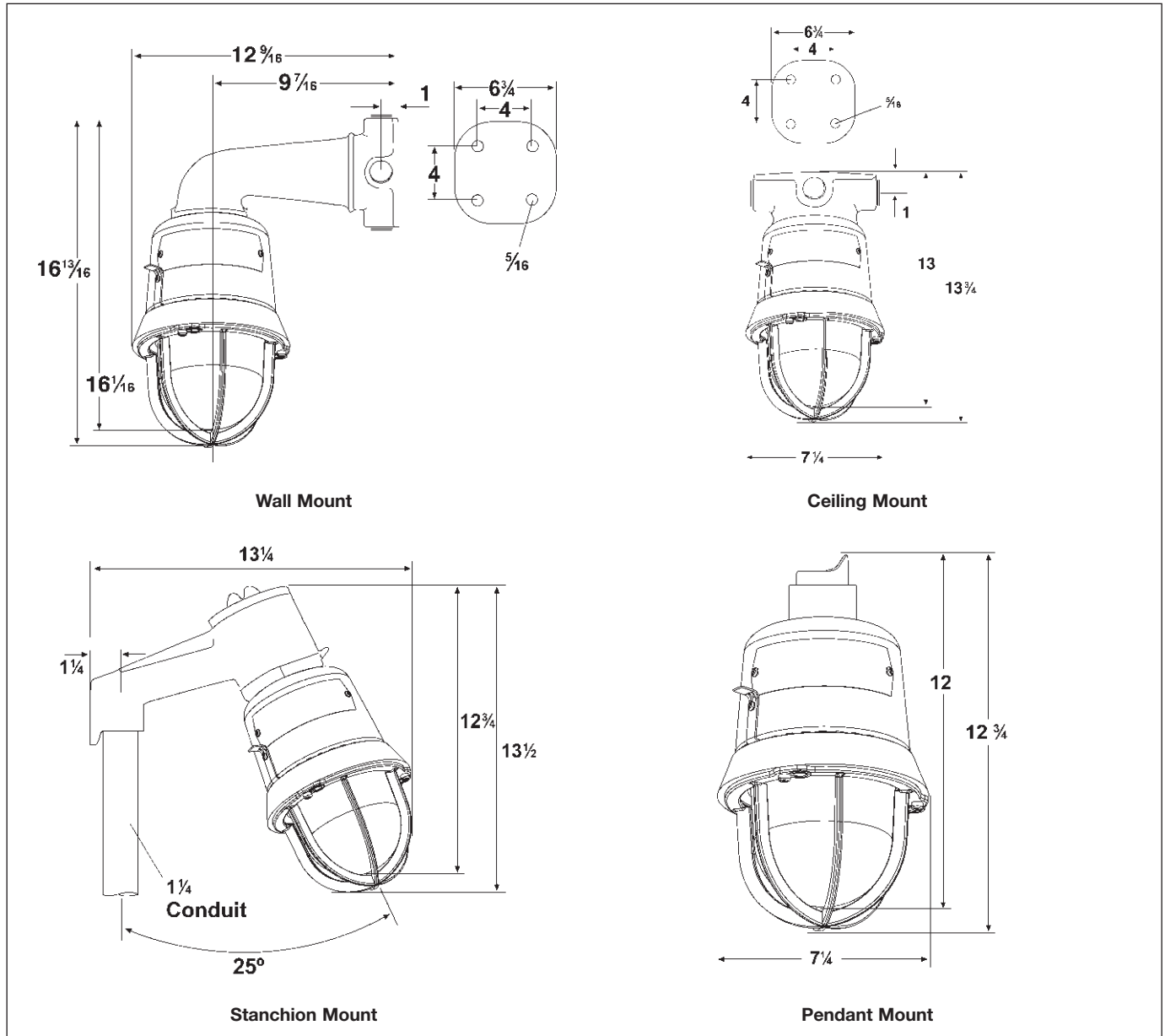

Net Luminaire Weights:

Type	lbs.
Luminaire Housing with Guard	11.0
Add mounting modules:	
Pendant	1.0
Ceiling	1.0
Wall	4.5
Stanchion	2.5

MEDC Series

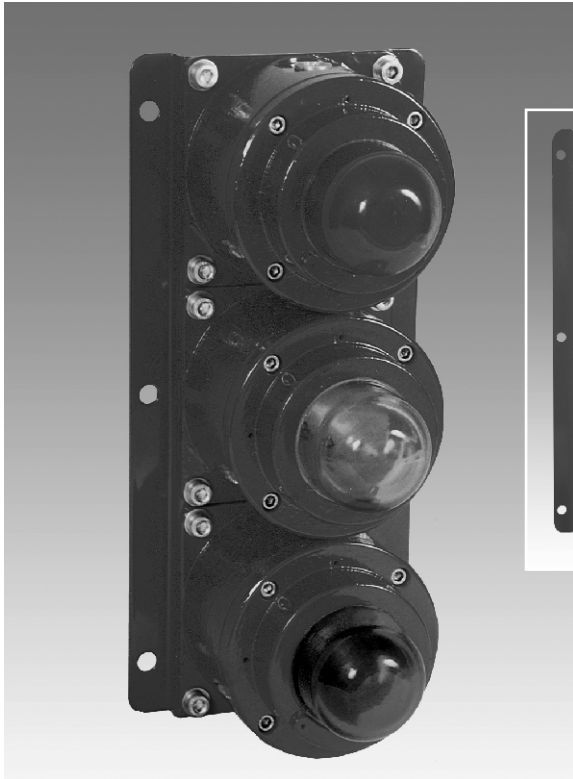

SM87 SL



XB12 SL

NOTE: Units shown are for representation only. Other variations are available.

The most rugged and reliable status lights for harsh and hazardous applications.

Available as Xenon, incandescent and fluorescent beacons/strobes.

The SM87 SL range is manufactured in marine grade alloy and the XB12 SL in corrosion-free GRP to provide a wide range of status lights to suit your requirements.

All units can be supplied as 1, 2, 3, 4 or 5 stacks.

Applications:

- Process status
- Messaging
- Alert or emergency condition indication

Typical Industries:

- Offshore & onshore
- Energy exploration & transmission
- Refining
- Chemical & petrochemical
- Pharmaceutical

Features and Benefits:

- 4-wire monitored connection for supervisory circuits*
- Marine grade alloy or GRP
- Pre-wired to customer's requirements

Certifications and Compliances:

- UL Listed for USA and Canada*
Class I, Div. 1 & 2, Groups C, D
Class I, Zone 1, AExd IIB T6
- CSA certified*
- ATEX approved
- Xenon, fluorescent, incandescent*
- NEMA 4X & 6, IP66 & 67
- Certified temperature -67°F to +131°F*
-55°C to +55°C

*Depending on model.

MEDC Series

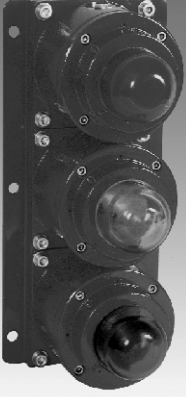
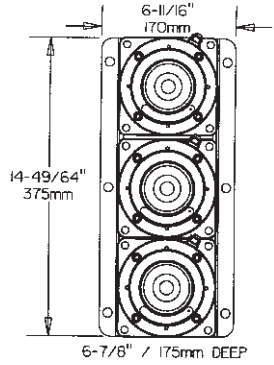
SM87 SL		Xenon, Incandescent & Fluorescent Status Lights—Explosionproof			
	Certification UL Listed for:	cULus, CSA, ATEX Class I, Div. 1, Groups C, D Class I, Zone 1, AExd IIB T4			
	Certified Ambient Temperature	-67°F to +158°F -55°C to +70°C			
	Ingress Protection	NEMA 4X & 6 IP66 & 67			
	Material	Alloy			
	Entries	Up to 1 x 1/2" NPT			
	Max. No. of Ways	4			
	Options	Body & lens color, certification, voltages 24–48V DC, 110–254V AC			
Certification	Voltage	Ordering Code	Cat. #	Standard Product Configuration	
UL, cUL Listed, Class I, Div. 1, Groups C, D	24V DC	26200043	SM87SL3	Explosion protected, three stack, one 1/2" NPT entry on bottom, no lens guards, xenon strobe with red, green, and clear lens	
UL, cUL Listed, Class I, Div. 1, Groups C, D	24V DC	26200055	SM87SL2	Xenon status lamp, two stack 5 joule beacons interconnected on a painted red stainless steel baseplate, one red and one green lens color, 1/2" NPT entry in the bottom unit for customer connection	
UL, cUL Listed, Class I, Div. 1, Groups C, D	24V DC	26200056	SM87SL2	Incandescent status lamp, two stack 40 watt beacons interconnected on a painted red stainless steel baseplate, one red and one green lens color, 1/2" NPT entry in the bottom unit for customer connection	
UL, cUL Listed, Class I, Div. 1, Groups C, D	24V DC	26200057	SM87SL2	Fluorescent status lamp, two stack 5 watt beacons interconnected on a painted red stainless steel baseplate, one red and one green lens color, 1/2" NPT entry in the bottom unit for customer connection	
UL, cUL Listed, Class I, Div. 1, Groups C, D	110V AC	26200058	SM87SL2	Xenon status lamp, two stack 5 joule beacons interconnected on a painted red stainless steel baseplate, one red and one green lens color, 1/2" NPT entry in the bottom unit for customer connection	
UL, cUL Listed, Class I, Div. 1, Groups C, D	24V DC	26200059	SM87SL3	Xenon status lamp, three stack 5 joule beacons interconnected on a painted red stainless steel baseplate, one red, one amber and one green lens color, 1/2" NPT entry in the bottom unit for customer connection	
UL, cUL Listed, Class I, Div. 1, Groups C, D	24VDC	26200060	SM87SL3	Incandescent status lamp, three stack 40 watt beacons interconnected on a painted red stainless steel baseplate, one red, one amber and one green lens color, 1/2" NPT entry in the bottom unit for customer connection	
UL, cUL Listed, Class I, Div. 1, Groups C, D	24V DC	26200061	SM87SL3	Fluorescent status lamp, three stack 5 watt beacons interconnected on a painted red stainless steel baseplate, one red, one amber and one green lens color, 1/2" NPT entry in the bottom unit for customer connection	
UL, cUL Listed, Class I, Div. 1, Groups C, D	110V AC	26200062	SM87SL3	Xenon status lamp, three stack 5 joule beacons interconnected on a painted red stainless steel baseplate, one red, one amber and one green lens color, 1/2" NPT entry in the bottom unit for customer connection	
UL, cUL Listed, Class I, Div. 1, Groups C, D	110V AC	26200066	SM87SL3	Incandescent status lamp, three stack 40 watt beacons interconnected on a painted red stainless steel baseplate, one red, one amber and one green lens color, 1/2" NPT entry in the bottom unit for customer connection	
UL, cUL Listed, Class I, Div. 1, Groups C, D	220V AC	26200063	SM87SL3	Fluorescent status lamp, three stack 5 watt beacons interconnected on a painted red stainless steel baseplate, one red, one amber and one green lens color, 1/2" NPT entry in the bottom unit for customer connection	

MEDC Series

XB11 SLUL Xenon Strobe & Incandescent Status Lights—Hazardous Locations



Certification UL Listed for:	UL, ATEX Class I, Div. 2, Groups C, D Class I, Zones 1 & 2, AExd IIB T4
Certified Ambient Temperature	-67°F to +158°F -55°C to +70°C
Ingress Protection	NEMA 4X & 6 IP66 & 67
Material	Corrosion-free GRP
Entries	1 x 1/2" NPT
Max. No. of Ways	5
Options	Body & lens color, tag & duty labels

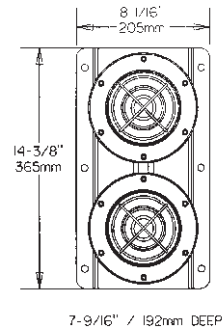

Certification	Ordering Code	Cat. #	Standard Product Configuration
---------------	---------------	--------	--------------------------------

UL Listed, Class I, Div. 2, Groups C, D	42500005	XB11ULSL3	Explosion protected, 3 stack, one 1/2" NPT entry on bottom, 24V DC, green incandescent on top, yellow xenon flashing in middle, red xenon flashing on bottom, no lens guards, red finish
---	----------	------------------	--

XB12 SL/FB12 SL Xenon Strobe & Incandescent Status Lights—Hazardous Locations



Certification UL Listed for:	UL, ATEX Class I, Div. 2, Groups C, D Class I, Zones 1 & 2, AExd IIB T4
Certified Ambient Temperature	-67°F to +158°F -55°C to +70°C
Ingress Protection	NEMA 4X & 6 IP66 & 67
Material	Corrosion-free GRP
Entries	1 x 1/2" NPT
Max. No. of Ways	5
Options	Body & lens color, certification, voltages 24V DC, 110–254V AC

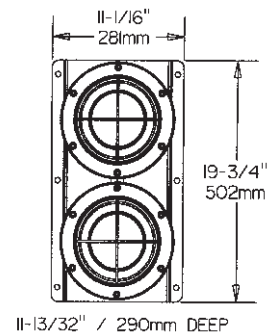

Certification	Ordering Code	Cat. #	Standard Product Configuration
---------------	---------------	--------	--------------------------------

UL Listed, Class I, Div. 2, Groups C, D	42600001	XB12ULSL3	110V AC, explosion protected, three stack , one 1/2" NPT entries, red xenon flashing on top, amber xenon flashing in middle, clear xenon flashing on bottom; no lens guards, red finish
UL Listed, Class I, Div. 2, Groups C, D	42600007	XB12ULSL2	24V DC xenon status lamp, two stack 21 joule beacons interconnected on a painted red stainless steel baseplate, one red and one green lens color, 1/2" NPT entry in the bottom unit for customer connection
UL Listed, Class I, Div. 2, Groups C, D	42600008	FB12ULSL2	24V DC incandescent status lamp, two stack 60W beacons interconnected on a painted red stainless steel baseplate, one red and one green lens color, 1/2" NPT entry in the bottom unit for customer connection
UL Listed, Class I, Div. 2, Groups C, D	42600009	XB12ULSL3	24V DC xenon status lamp, three stack 21 joule beacons interconnected on a painted red stainless steel baseplate, one red, one amber and one green lens color, 1/2" NPT entry in the bottom unit for customer connection
UL Listed, Class I, Div. 2, Groups C, D	42600010	FB12ULSL3	24V DC incandescent status lamp, three stack 60W beacons interconnected on a painted red stainless steel baseplate, one red, one amber and one green lens color, 1/2" NPT entry in the bottom unit for customer connection

MEDC Series

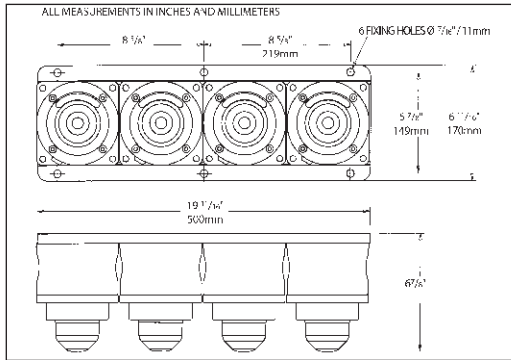

SM87 SL

Typical four unit assembly. Various options are available.

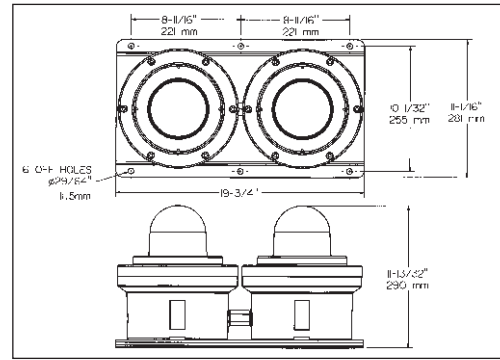

XB12 SL

Typical two unit assembly. Various options are available.

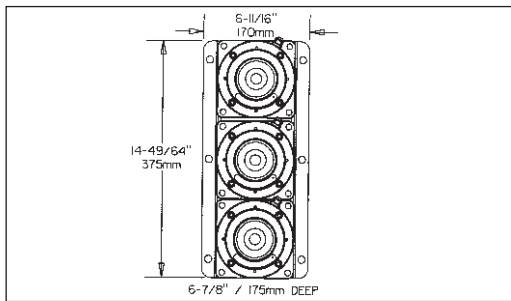

SM87 SL typical three unit assembly

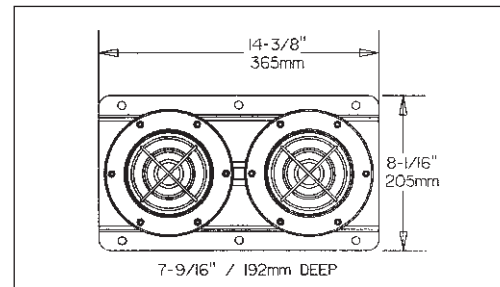

XB11 SL

Specification—SM87SL Unit and XB12SL Unit

	SM87 SL	XB12 SL
Lamp Types	Xenon 5 joules maximum Fluorescent 10W or 5W Incandescent 40W maximum	Xenon 21 joules Incandescent 60W
Voltage Frequency	50 Hz as standard. 60 Hz available if required.	
Xenon Voltages	24, 48V DC 110, 120, 240, 254V AC (see SM87 HXB data sheet for further information)	24V DC, 110V, 240V AC (see XB12 data sheet for further information)
Incandescent Voltages	12, 24, 48V DC, 110, 220, 240, 254V AC (see SM87 LU3 data sheet for further information)	120V AC (see FB12 data sheet for further information)
Fluorescent Voltages	12, 24, 48V, 220, 240, 254V AC (see SM87 LU1 data sheet for further information)	-
Lamp Colors	Red, Amber, Yellow, Green, Blue or Clear	
Certification	UL Listed for USA and Canada Class I, Div. 1, Groups C, D, Class I, Zone 1, AExd IIB T6. Listing No. E187894. CSA Certified: Class I, Div. 1 & 2, Group D. Cert. No. 96406. ATEX Approved: Exd IIC T4 (incandescent), Exd IIC T6 (Fluorescent & Xenon) Cert. No. Baseefa 03ATEX0222X CENELEC EN50014, EN50018	UL Listed for USA and Canada Class I, Div. 2, Groups C, D, Class I, Zones 1 & 2, AExd IIB T4/T5 Listing No. E187894 ATEX Approved: Exd IIB T4/T5 Cert. No. 99 ATEX 2196 CENELEC EN50014 and EN50018
Terminals	Will accept up to 14AWG cable	Will accept up to 6 off 10AWG cable
Wiring	Standard configuration of internal wiring is to common the negative/neutral connections If individually wired lamps are required, please state requirements	
Entries	Up to 3 x 1/2" or 3/4" NPT	1 x 1/2" NPT
Enclosure	LM 25TF Marine Grade Alloy	GRP
Lens	Glass	
Finish	Epoxy paint as standard or to customer's specification	Natural black or epoxy paint to customer's specification
Ingress Protection	NEMA 4X and 6, IP66 & 67	
Ambient Temp.	-13°F to 131°F (-25°C to +55°C) – Class I, Div 1 -67°F to +131°F (-55°C to +55°C) – Class I, Zone 1	-67°F to +158°F (-55°C to +70°C)

NOTE: XB11 SLUL also available.

4S

Up to 30 Watts

Loudspeakers and tone generators provide high decibel communication for messaging, alert and evacuation in harsh and hazardous locations.

- Metallic and non-metallic housings
- Explosionproof and Class I, Division 2 horns and speakers
- Mounting brackets that allow a full 180° swivel
- Products designed for both conduit wiring and/or cable connection (NPT or metric entries available)
- Selectable tones

This range of loudspeakers, intended for use in potentially explosive gas and dust atmospheres, has a power rating of up to 30 Watts and is suitable for use in the harsh environmental conditions found offshore and onshore in the oil, gas and petrochemical industries.

The flamepaths, flare and body, are manufactured from a UV stable glass reinforced polyester. Stainless steel screws and mounting stirrup are incorporated to ensure a corrosion-free product.

Applications:

- Plant-wide alarm notification
- Audible process alarms

Typical Industries:

- Refineries
- Chemical plants
- Oil and gas exploration
- Marine terminals for transportation & storage



DB16

Certifications and Compliances:

- UL Listed for USA and Canada
 - Hazardous locations:
 - Class I, Div. 2, Groups A, B, C, D*
 - Class I, Zone 1, AExde IIB/IIC T3/T4*
 - Ordinary locations: Signalling Speaker
- ATEX approved
- NEMA 4X & 6, IP66 and IP67
- Certified temperature:
 - 67°F to +104°F
 - 50°C to +40°C

Features and Benefits:

- GRP corrosion-free flamepath
- Up to 112dBA at 30 Watts at 10 feet*
- Power tapings via integral transformer
- Ratcheted swivel mounting stirrup
- Stainless steel fixtures
- 100V line or 8 ohm versions available

*Model dependent.

Up to 30 Watts

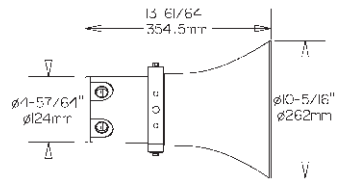
DB16 UL		30 Watt Speaker – Hazardous & Ordinary Locations	
	Certification UL Listed for:	cULus, ATEX Class I, Div. 2, Groups C, D / A, B, C, D Class I, Zone 1, AExde IIB T3/IIC T110°C	
	Certified Ambient Temperature	-61°F to +90°F -50°C to +40°C	
	Ingress Protection	NEMA 4X & 6 IP66 & 67	
	Material	Corrosion-free GRP	
	Output	Groups C & D:100dB(A) at 1Watt at 10 ft. 112dB(A) at 30 Watts at 10 ft.	
	Groups A, B, C, D:	3dB(A) less than C & D versions	
	Entries	Up to 2 x 1/2" NPT or 2 x 3/4" NPT, 20mm, 25mm	
	Weight	12.1lb/5.5kg	
	Tappings @ 30 Watts	30, 25, 12, 6, 4, 2	
	Options:	Body color, transformer	
Certification	Ordering Code	Cat. #	Standard Product Configuration
UL, cUL Listed, Class I, Div 2, Groups C & D	28600006	DB16UCXN2MPN	Unit suitable for gas Groups A, B, C, D, 70V line transformer, 2 x 1/2" NPT, one certified plug, natural black finish

Up to 30 Watts

Specification – DB16 Unit

Rated Power:	30 Watts RMS continuous (at 77°F/25°C)
Certification:	<p>UL Listed for USA and Canada</p> <p>– Hazardous locations: Class I, Div. 2, Groups C, D, Class I, Zone 1, AExde IIB T3 Class I, Div. 2, Groups A, B, C, D, Class I, Zone 1, AExde IIC T110°C UL Listing No. E203310</p> <p>– Ordinary locations: Signalling Speaker; UL Listing No. 58847 CENELEC EN50014, 18, 19</p> <p>IIB Version: Cert. No. Baseefa04ATEX0166X ATEX Ex II 2G Exde IIB T3 (Tamb. -50°C to +40°C)</p> <p>IIC Version: Cert. No. Baseefa04ATEX0167X ATEX Ex II 2GD Exde IIC T110°C (Tamb. -50°C to +40°C)</p> <p>Zones 1 and 2</p>
Material:	Body & horn in anti-static, UV stable, glass reinforced polyester Mounting stirrup and fixtures in stainless steel
Finish:	All natural or body and horn can be painted to client's requirements
Output:	<p>Groups C, D Version: Maximum output at 1W at 10 feet is 100dBA Maximum output at 30W at 10 feet is 112dBA</p> <p>Groups A, B, C, D Version: Maximum output at 1W at 10 feet is 97dBA Maximum output at 30W at 10 feet is 109dBA</p>
Weight:	12lb/5.5kg approx.
Certified Temperature:	67°F to +104°F (-50°C to +40°C)
Ingress Protection:	NEMA 4X & 6, IP66 & IP67
Voltage:	370Hz to 8kHz
Voice Coil Impedance:	8 ohms
Transformer:	Used by combining the rated power tapings below

Transformer Tapping Options:

Transformer Tappings	Power (W)
1:2	30
2:3	25
3:4	12
1:3	6
2:4	4
1:4	2

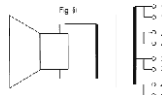

(i) Loop in/loop out (4 x 2) power tap change; 8 terminals

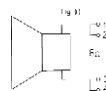

(ii) Loop in/loop out (2 x 2) 8 ohm; 4 terminals

Terminals:	8 x 2.5mm ²
Earth Continuity:	Available via optional earthing stud or by internal earth plate
Mounting:	Via stirrup with ratchet facility
Labels:	Optional stainless steel tag and duty labels
Cable Entries:	Up to 2 x 1/2" NPT or 2 x 3/4" NPT into termination chamber, 20mm, 25mm

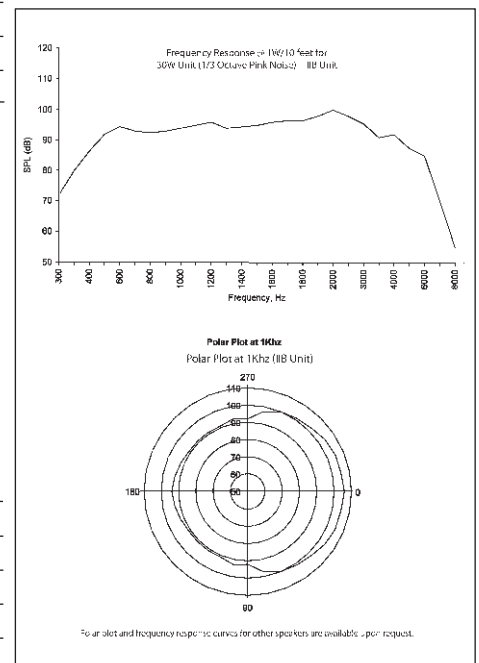
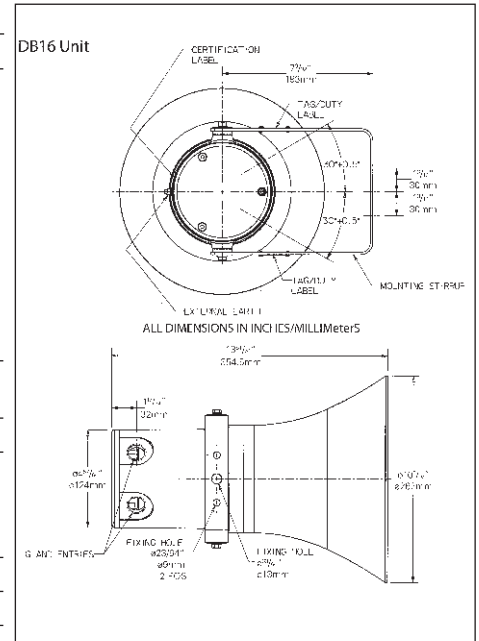

Ordering Requirements

The following code is designed to help in the selection of the correct unit. Build up the reference number by inserting the code for each component into the appropriate box.

DB16	Certification	Transformer	Options	Entries	Finish																																								
			N																																										
	<table border="1"> <thead> <tr> <th>Certification</th> <th>Code</th> </tr> </thead> <tbody> <tr> <td>UL (A, B, C, D)</td> <td>UC</td> </tr> <tr> <td>ATEX IIC</td> <td>BC</td> </tr> </tbody> </table> <p>Unit suitable for gas groups.</p>	Certification	Code	UL (A, B, C, D)	UC	ATEX IIC	BC	<table border="1"> <thead> <tr> <th>Transformer</th> <th>Code</th> </tr> </thead> <tbody> <tr> <td>Yes</td> <td>X*</td> </tr> <tr> <td>No</td> <td>N</td> </tr> </tbody> </table> <p>*Std 100V. Other voltages available, specify voltage.</p>	Transformer	Code	Yes	X*	No	N	<table border="1"> <thead> <tr> <th>Options</th> <th>Code</th> </tr> </thead> <tbody> <tr> <td>N</td> <td></td> </tr> </tbody> </table>	Options	Code	N		<table border="1"> <thead> <tr> <th>Entries</th> <th>Code</th> </tr> </thead> <tbody> <tr> <td>1 x M20</td> <td>1B</td> </tr> <tr> <td>2 x M20</td> <td>2B</td> </tr> <tr> <td>1 x M25</td> <td>1C</td> </tr> <tr> <td>2 x M25</td> <td>2C</td> </tr> <tr> <td>1 x 1/2" NPT</td> <td>1M</td> </tr> <tr> <td>2 x 1/2" NPT</td> <td>2M</td> </tr> <tr> <td>1 x 3/4" NPT</td> <td>1N</td> </tr> <tr> <td>2 x 3/4" NPT</td> <td>2N</td> </tr> </tbody> </table> <p>To specify certified plug, suffix appropriate code with 'P', e.g. 2B-P is 2 x M20 entries with one certified plug.</p>	Entries	Code	1 x M20	1B	2 x M20	2B	1 x M25	1C	2 x M25	2C	1 x 1/2" NPT	1M	2 x 1/2" NPT	2M	1 x 3/4" NPT	1N	2 x 3/4" NPT	2N	<table border="1"> <thead> <tr> <th>Option</th> <th>Code</th> </tr> </thead> <tbody> <tr> <td>Natural Black</td> <td>N</td> </tr> <tr> <td>Red</td> <td>R</td> </tr> </tbody> </table>	Option	Code	Natural Black	N	Red	R
Certification	Code																																												
UL (A, B, C, D)	UC																																												
ATEX IIC	BC																																												
Transformer	Code																																												
Yes	X*																																												
No	N																																												
Options	Code																																												
N																																													
Entries	Code																																												
1 x M20	1B																																												
2 x M20	2B																																												
1 x M25	1C																																												
2 x M25	2C																																												
1 x 1/2" NPT	1M																																												
2 x 1/2" NPT	2M																																												
1 x 3/4" NPT	1N																																												
2 x 3/4" NPT	2N																																												
Option	Code																																												
Natural Black	N																																												
Red	R																																												

Factory Sealed

Applications:

ETH horn signals are used:

- For call signals, alarms, and various other signalling applications
- In specific hazardous atmospheres as found in chemical plants, oil and gas refineries, bulk loading stations, paint and varnish manufacturing plants, grain processing industries and grain elevators, as well as in certain metal, coal, combustible fiber processing or handling areas
- In conduit systems and mounted on a flat surface with the projectors aimed in the desired direction

Features:

- No external conduit seal is required.
- The AC signals do not have arcing contacts.
- The DC horns have factory sealed wire leads in the interconnecting nipple and hub.
- The body cover joint of AC horn signals is of serrated construction, machined to close tolerance to ensure flametightness and secured by a clamping ring. The DC unit has a ground joint design.

Certifications and Compliances:

- NEC:
 - Class I, Division 1 & 2, Groups B†, C, D
 - Class II, Division 1, Groups E, F, G
 - Class II, Division 2, Groups F, G
 - Class III
- UL Standard: 464, 1203
- CSA Standard: C22.2 No. 30

Standard Materials:

- Copper-free aluminum

Standard Finishes:

- Natural

Size Ranges:

- Hub – 1/2" or 3/4" size

Sound Levels:

- See Ordering Information table for individual ratings

Electrical Rating Ranges:

- Nominal voltage – 24, 115, 230 VAC 24 VDC

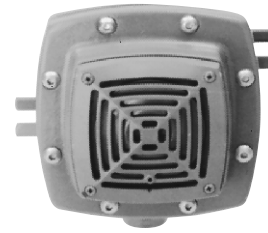

ETH grill type horn signal

Table 1
Operating Current in Amperes at the Nominal Voltage for Horn and Siren Signals

Horn Signal			
	Amperes	Grill Type	
	Single Projector	50 to 60 hertz AC	
		ETH2313, ETH2316, ETH2312	DC ETH2416
Nom. Volts	50 to 60 hertz AC ETH2702, ETH2703		
24	—	0.625	0.16
115	.45	0.13	
230	.2	0.065	

Ordering Information:

Supply	Nom. Volts*	Nom. Watts	Minimum audibility rating (dB) at 10':	Hub Size	Cat. #
Single Projector Horn Signal					
50 to 60 hertz AC	115	33	105 dB	1/2	ETH2703
230	230	33	105 dB	1/2	ETH2702
Grill Type Horn Signals					
50 to 60 hertz AC	24		100 dB	3/4	ETH2316
	115	49	100 dB	3/4	ETH2313
	230		100 dB	3/4	ETH2312
DC	24	30	100 dB	3/4	ETH2416

Dimensions

In Inches:

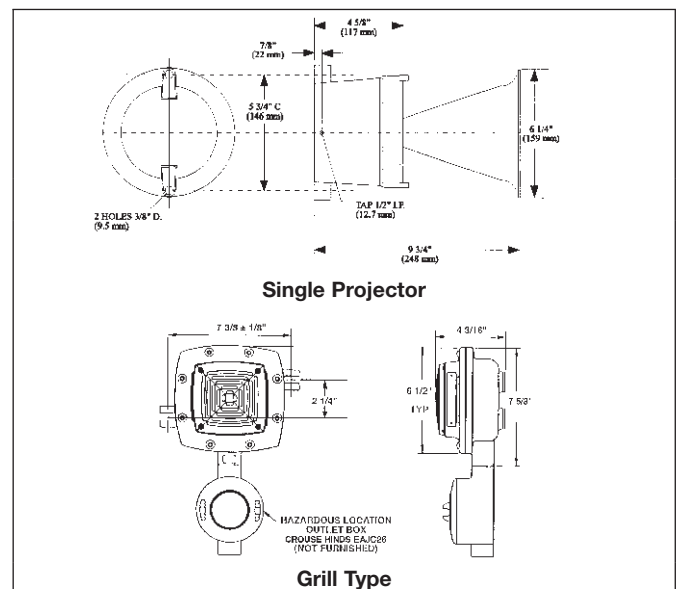

Dimensions are approximate, not for construction purposes.

†Grill type horns are certified for Group B.
 * See Table 1 for more complete ratings

EGL Static Grounding Indicator

With Automated Pump Control and Static Ground Verification System

Cl. I, Div. 1 & 2, Groups B, C, D
 Cl. I, Zone 1 & 2 IIB + H₂
 Cl. II, Div. 1, Groups E, F, G
 Cl. II, Div. 2, Groups F, G
 Cl. III

UL/cUL Listed
 NEMA 3, 4X, 7BCD, 9FG, 12
 Explosionproof
 Dust-Ignitionproof
 Raintight / Wet Locations

5C

Applications:

EGL Static Grounding Indicator is the ideal product for safe loading/unloading of ethanol, biofuel, petroleum, chemicals, plastics and other combustible materials. The EGL is mounted adjacent to loading/unloading areas and connected to transportation tank vehicles, railcars, drums or other portable containers to prevent explosions due to static discharge during product transfer by providing:

- A ground path for static build-up
- Automatic pump shutdown when static grounding circuit is broken
- Visual indication of safe, static grounding before, during and after loading and unloading operations

Features and Benefits:

- Static ground verification system provides ground path for static build-up to ensure safe product transfer
- Integrated control relay allows for safe control of electrically operated pumps or valves, and for energizing remote indicators
- Stainless steel clamp for grounding connection provides industrial durability, corrosion resistance, and increased product lifetime
- Interior and exterior epoxy powdered paint finish provides superior corrosion resistance inside and out
- LED pilot lights provide long-lasting visual identification of status of ground connection
- ECD Type 4X drain protects interior equipment from environmental moisture and condensation, rain water, and hose-down applications
- NEMA 4X compact, hose-tight, and corrosion-resistant enclosure offers years of service in harsh industrial environments
- 25 ft. safety fluorescent yellow cord is easily identifiable to ensure safety and reduce tripping hazard
- Neoprene cover gasket provides a watertight seal to meet UL Type 4 (NEMA 4) requirements
- Stainless steel hinges are corrosion resistant while providing safe and easy access to interior of enclosure
- Waterguard™ desiccant packet absorbs and removes water/moisture and protects the enclosed equipment when not energized
- Adjustable mounting feet provide ease of mounting during installation

Certifications & Compliances:

- Class I, Divisions 1 & 2, Groups B, C, D
- Class II, Division 1, Groups E, F, G
- Class II, Division 2, Groups F, G
- Class III
- Class I, Zone 1&2 IIB + H₂
- UL/cUL Listed
- IP 65
- NEMA 3, 4X, 7BCD, 9FG, 12

Standard Materials:

- Enclosure: Copper-free aluminum with interior and exterior epoxy powder coat
- Clamp: Stainless steel
- Clamp Grips: Polyvinylchloride dipped
- Gasket: Neoprene

Electrical Rating Ranges:

- Power consumption: 9.8VA
- 120-volt AC supply
- Control relay interlocking contact: 15A at 277VAC; 10A at 600VAC
- Dual-tapped 240 and 480 VAC Step Down Transformer available
- Provides 2k ohms or less switching impedance
- 50/60 Hz

Crouse-Hinds

by **Eaton**



Ordering Information:

Description
 Indicator with two pilot lights*

Catalog Number
 EGL210 J1 J3

*Includes one red and one green pilot light.

Options:

Description	Suffix
Internal space heaters to limit condensation build-up	R11
Transformer suitable for both 220/240VAC or 440/480VAC applications	S883
50 foot cord	50FC

Options:

Replacement Parts:

Ground clamp	EGL-K1
Ground clamp assembly (includes 25 ft. cord, connector and clamp)	EGL:20109-B
EGL210 universal interior replacement kit	EGL210-R1
Pilot lights (Red)	EMP009-J1-LED
Pilot lights (Green)	EMP009-J3-LED
Mounting feet	EJB-KIT5
Transformer (220/240VAC; 440/480VAC)	EGL S883 KIT
Space heater	EGL R11 KIT
Pilot light plug kit	EGL PLUG KIT

Weight & Dimensions:

EGL Assembly:

Weight = 32 lbs (14.5 kg)

Dimensions = inches (centimeters)

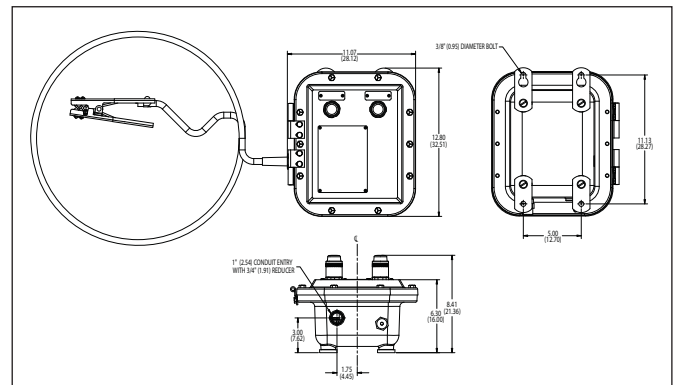

5C

Luces de Obstrucción Serie LO y CLO

Los faros LO son usados en aeronavegación como luces de señalización de obstáculos, para torres de comunicación, silos, chimeneas, tanques, edificios u objetos de gran dimensión que necesiten ser señalados en la noche. (Tipo L-810 según FAA) (Baja intensidad tipo B según OACI).

APLICACIONES

- Para señalización perimetral.
- Como luces de información de proceso en plantas industriales, para advertir, comunicar, o llamar la atención sobre un área, máquina o proceso.

CARACTERÍSTICAS

- Protección contra la intemperie NEMA 4X. (IP 65).
- Lente de vidrio de fresnel rojo omnidireccional.
- Cuerpo en fundición de aluminio de bajo contenido de cobre.
- Conexión NPT 3/4" (estándar).
- Tipo de conexión E27 (Para luces de aeronavegación y para la fotometría presentada; sólo se usa Bombillo LED suministrado por el fabricante).
- Seguro del lente tipo abrazadera en acero inoxidable.
- Lente y abrazadera asegurados con guaya para prevenir caídas y rupturas del lente.
- Diseñado de acuerdo a OACI y FAA.
- Se suministra con bombillo LED de larga duración y eficiencia.

BENEFICIOS

- Largo tiempo de vida gracias a su lente de vidrio que no se degrada con la intemperie, acabado con pintura electrostática y al seguro tipo abrazadera de acero inoxidable.
- Fácil acceso gracias a su seguro tipo abrazadera, se puede cambiar la lámpara sin utilizar herramienta.
- Bajo consumo de energía y larga duración (se suministra con bombillo LED 9.5W)
- Diseñada bajo normatividad aeronáutica.
- Puede funcionar con unidades de control fotoeléctrico e intermitentes.



CUMPLIMIENTOS

- Cumple como luz de obstrucción tipo L-810 Según FAA (con la referencia de bombillo suministrado).
- Cumple como luz de baja intensidad tipo B Según OACI (con la referencia de bombillo suministrado).

MATERIALES

- Cuerpo en aluminio con bajo contenido de cobre.
- Lente de vidrio de fresnel rojo omnidireccional.
- Abrazadera de acero inoxidable.
- Empaque en caucho.
- Acabado en pintura amarilla electrostática.

EGL Static Grounding Indicator

With Automated Pump Control and Static Ground Verification System

Cl. I, Div. 1 & 2, Groups B, C, D
 Cl. I, Zone 1 & 2 IIB + H₂
 Cl. II, Div. 1, Groups E, F, G
 Cl. II, Div. 2, Groups F, G
 Cl. III

UL/cUL Listed
 NEMA 3, 4X, 7BCD, 9FG, 12
 Explosionproof
 Dust-Ignitionproof
 Raintight / Wet Locations

5C

Applications:

EGL Static Grounding Indicator is the ideal product for safe loading/unloading of ethanol, biofuel, petroleum, chemicals, plastics and other combustible materials. The EGL is mounted adjacent to loading/unloading areas and connected to transportation tank vehicles, railcars, drums or other portable containers to prevent explosions due to static discharge during product transfer by providing:

- A ground path for static build-up
- Automatic pump shutdown when static grounding circuit is broken
- Visual indication of safe, static grounding before, during and after loading and unloading operations

Features and Benefits:

- Static ground verification system provides ground path for static build-up to ensure safe product transfer
- Integrated control relay allows for safe control of electrically operated pumps or valves, and for energizing remote indicators
- Stainless steel clamp for grounding connection provides industrial durability, corrosion resistance, and increased product lifetime
- Interior and exterior epoxy powdered paint finish provides superior corrosion resistance inside and out
- LED pilot lights provide long-lasting visual identification of status of ground connection
- ECD Type 4X drain protects interior equipment from environmental moisture and condensation, rain water, and hose-down applications
- NEMA 4X compact, hose-tight, and corrosion-resistant enclosure offers years of service in harsh industrial environments
- 25 ft. safety fluorescent yellow cord is easily identifiable to ensure safety and reduce tripping hazard
- Neoprene cover gasket provides a watertight seal to meet UL Type 4 (NEMA 4) requirements
- Stainless steel hinges are corrosion resistant while providing safe and easy access to interior of enclosure
- Waterguard™ desiccant packet absorbs and removes water/moisture and protects the enclosed equipment when not energized
- Adjustable mounting feet provide ease of mounting during installation

Certifications & Compliances:

- Class I, Divisions 1 & 2, Groups B, C, D
- Class II, Division 1, Groups E, F, G
- Class II, Division 2, Groups F, G
- Class III
- Class I, Zone 1&2 IIB + H₂
- UL/cUL Listed
- IP 65
- NEMA 3, 4X, 7BCD, 9FG, 12

Standard Materials:

- Enclosure: Copper-free aluminum with interior and exterior epoxy powder coat
- Clamp: Stainless steel
- Clamp Grips: Polyvinylchloride dipped
- Gasket: Neoprene

Electrical Rating Ranges:

- Power consumption: 9.8VA
- 120-volt AC supply
- Control relay interlocking contact: 15A at 277VAC; 10A at 600VAC
- Dual-tapped 240 and 480 VAC Step Down Transformer available
- Provides 2k ohms or less switching impedance
- 50/60 Hz

Crouse-Hinds

by **Eaton**



Ordering Information:

Description
Indicator with two pilot lights*

Catalog Number
EGL210 J1 J3

*Includes one red and one green pilot light.

Options:

Description	Suffix
Internal space heaters to limit condensation build-up	R11
Transformer suitable for both 220/240VAC or 440/480VAC applications	S883
50 foot cord	50FC

Options:

Replacement Parts:

Ground clamp	EGL-K1
Ground clamp assembly (includes 25 ft. cord, connector and clamp)	EGL:20109-B
EGL210 universal interior replacement kit	EGL210-R1
Pilot lights (Red)	EMP009-J1-LED
Pilot lights (Green)	EMP009-J3-LED
Mounting feet	EJB-KIT5
Transformer (220/240VAC; 440/480VAC)	EGL S883 KIT
Space heater	EGL R11 KIT
Pilot light plug kit	EGL PLUG KIT

Weight & Dimensions:

EGL Assembly:

Weight = 32 lbs (14.5 kg)

Dimensions = inches (centimeters)

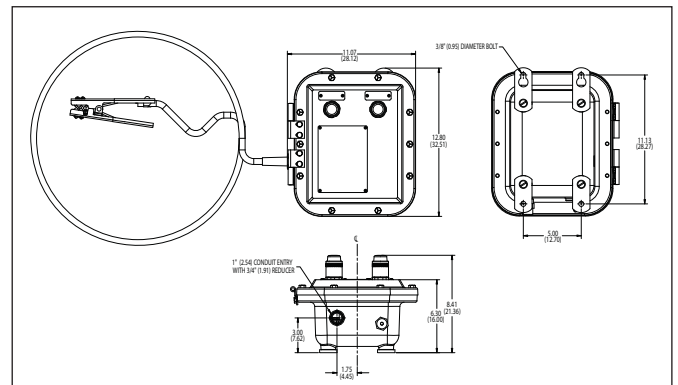

5C

Luces de Obstrucción serie LO y CLO

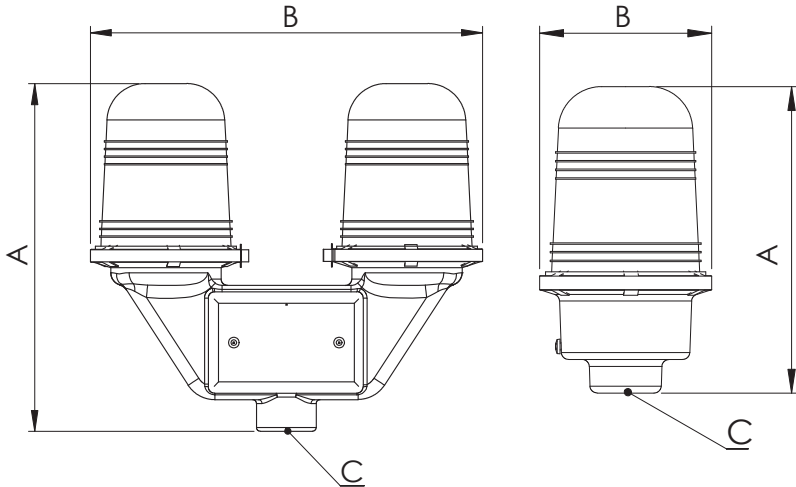

RANGO ELÉCTRICO

- 120 VAC 9.5W.

OPCIONES DE PRODUCTO

- La conexión puede ser roscada NPT 1"
- Puede venir en unidad doble (back up).
- El color del lente se puede suministrar en transparente, verde, azul o amarillo.

GARANTÍA

- Un año por defectos de fábrica.

Referencia	Vataje (W)	Voltaje (VAC)	Tipo Bombillo	Dimensiones (mm)		Acceso C	Masa (kg)
				A	B		
LO-1L	10	120	LED 9.5 W	212	119	3/4 Npt	1.4
CLO-1L	20	120	LED 9.5 W	275	310	3/4 Npt	2.8

Fotometría

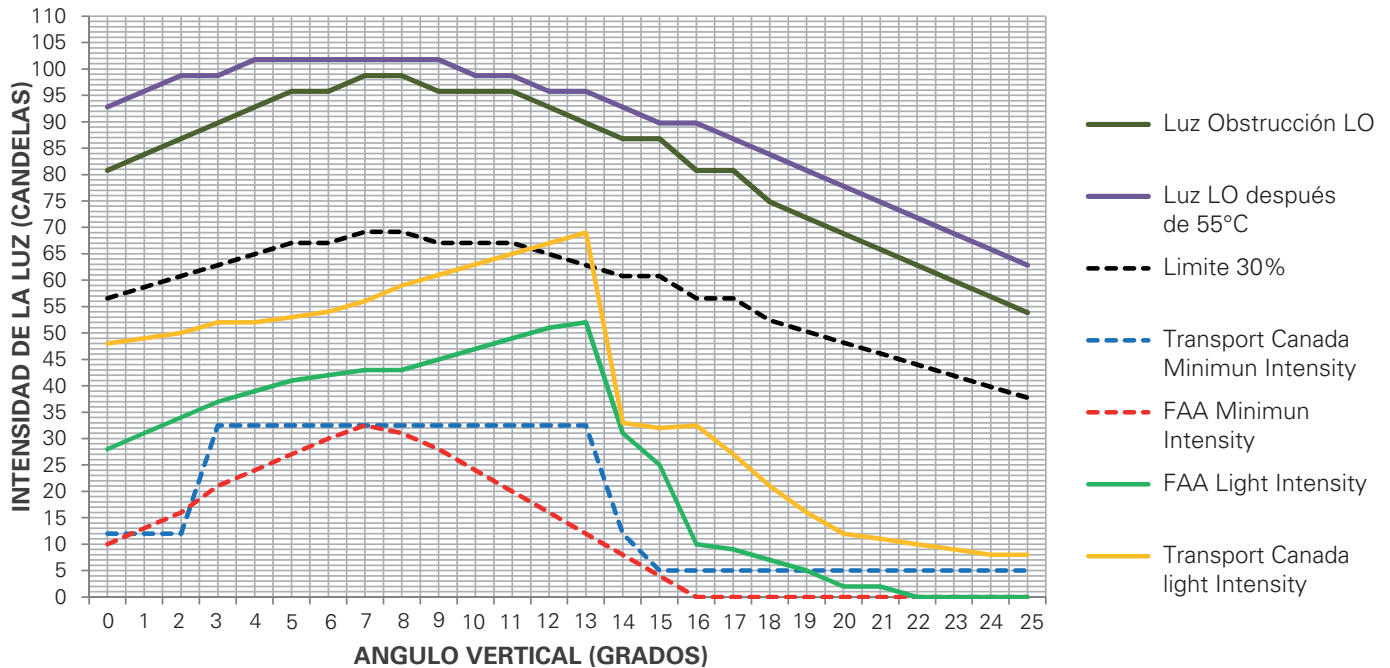

Control de Luces de Obstrucción Serie IE

APLICACIONES

- El control fotoeléctrico serie IE, controla desde 1 a 4 luces de obstrucción tipo L-810 según FAA o luces de baja intensidad tipo B según OACI, que funcionen con bombillos LED únicamente.
- Diseñados para funcionar en modo nocturno.
- Encienden de noche, apagan de día, adicionalmente controla intermitencia, back up y rotación de luces para desgaste uniforme de bombillos.

CARACTERÍSTICAS

- Protección contra la intemperie NEMA 4X. (IP 65).
- Funciona con alimentación 120 VAC 60Hz.
- Controla únicamente bombillos LED hasta 20W cada uno.
- Potencia consumida por la unidad 1W
- Indicador LED de encendido (interno).
- Indicador LED de falla (interno).
- Circuitos en estado sólido para una alta confiabilidad.
- La programación inicial con que sale el producto de fabrica es intermitencia, aunque permite escoger cualquier otro modo de programación.
- 12 modos de programación.
- Foto-control dirigitible.



BENEFICIOS

- Larga duración gracias a su electrónica en estado sólido.
- Bajo consumo de potencia eléctrica.
- Gran flexibilidad por contar con 12 modos de programación.
- Se puede instalar en la base del obstáculo para facilitar su mantenimiento.
- El control detecta bombillos dañados, facilitando las labores de mantenimiento.
- Cuenta con salida conmutable para conectar a panel de alarma, esta salida conmuta de posición una conexión para indicar que algún bombillo se fundió o sufrió daño.
- En los modos que están programados con back up, se aplica un modo de rotación de encendido de bombillos encendiendo un día un bombillo y al siguiente día el bombillo de back up, para que se desgasten de forma homogénea.



Iluminación

Control de Luces de Obstrucción Serie IE

CUMPLIMIENTOS

- Diseñado bajo normatividad FAA para control de luces de obstrucción tipo L810

MATERIALES

- Cuerpo en aluminio de bajo contenido de cobre.
- Tornillos en acero inoxidable.
- Acabado en pintura electrostática gris martillado.

RANGO ELÉCTRICO

- Alimentación 120 VAC 60Hz
- Potencia consumida 1W más la potencia de los bombillos que se conecten.
- Admite desde 1 hasta 4 bombillos tipo LED cada uno de máximo 20W

OPCIONES DE PRODUCTO

- La conexión puede ser roscada NPT 1".

GARANTÍA

- Un año por defectos de fábrica.

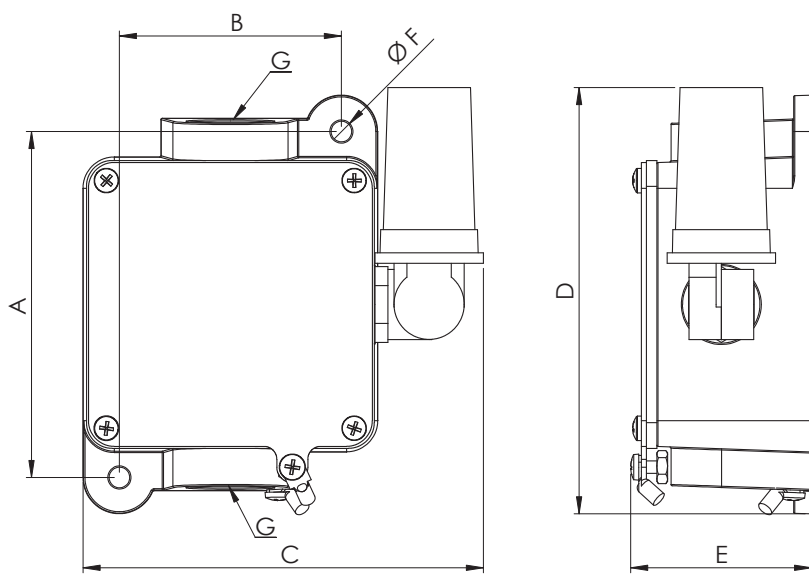

Referencia	Voltaje (VAC)	Dimensiones Intermitente IE (mm)						Conexión
		A	B	C	D	E	F	G
IE-1	120	134	86	155	165	70	8	3/4" NPT

Control de Luces de Obstrucción Serie IE



Modos de Operación para Luces de Obstrucción

Control	Luces	Luces Con Falla	#
	Fijo 1 2 3 4	Señal Daño 1 2 3 4	1
	Fijo Fijo 1 2 3 4	Señal Daño Fijo 1 o 2 Restante 3 4	2
	Fijo Fijo Fijo 1 2 3 4	Señal Daño Fijo Fijo 1,2 o 3 Restantes Restantes 4	3
	Fijo Fijo Fijo Fijo 1 2 3 4	Señal Daño Fijo Fijo Fijo Cualquiera Restantes Restantes Restantes	4
	Back up Fijo 1 2 3 4	Señal Fijo Daño 1 2 3 4	5
	Back up Fijo Back up Fijo 1 2 3 4	Señal Fijo Daño Fijo Daño 1 2 3 4	6
	Fijo Fijo Back up Fijo 1 2 3 4	Señal Fijo Fijo Fijo Daño 1 2 3 4	7
	Int Int alt 1 2 3 4	Señal Int Daño 1 o 2 1 o 2 3 4	8
	Int Int alt Int Int alt 1 2 3 4	Señal Daño Int alt Int Int alt Cualquiera Restantes Restantes Restantes	9
	Int Fijo 1 2 3 4	Señal Daño Fijo/int Cualquiera Restantes 3 4	10
	Int 1 2 3 4	Señal Daño 1 2 3 4	11
	Int Int Int 1 2 3 4	Señal Daño Int Int Cualquiera Restantes Restantes 4	12

Convenciones

	El bombillo enciende intermitente		El bombillo enciende constante		El bombillo no enciende por daño
	El bombillo enciende intermitente alternado con		El programa no tiene habilitada		
	Back up El bombillo no enciende, está en buena condición en espera de reparar un daño. La unidad de back up funcionará de modo alterno a la unidad que está repaldando, de tal modo que una noche enciende el bombillo mostrando en la gráfica y a la siguiente noche enciende la unidad de back up. Esto con el fin de garantizar un desgaste simultáneo y automático de los bombillos				

Luminaria para Pistas LA-1 iluram

Especialmente diseñada para áreas de no precisión en pistas de aterrizaje y despegue, pistas de rodaje.

Luz de obstrucción Tipo L-810 para borde de pista según FAA (Baja intensidad tipo B según OACI).

APLICACIONES

- Para señalización perimetral
- Pueden ser de tipo omnidireccional de colores: cristal, amarillo, azul, verde y rojo.
- Bidireccional con rojo, verde, azul o con cualquier otro tipo de combinación

CARACTERÍSTICAS

- Acople con sistema frangible de protección.
- Protección contra la intemperie NEMA 4X. (IP 65).
- Lente de vidrio de fresnel omnidireccional.
- Cuerpo en fundición de aluminio de bajo contenido de cobre.
- Acabado en pintura electrostática.
- Conexión NPT 3/4" (estándar).
- Acepta lámparas de conexión E27 (Para luces de aeronavegación y para la fotometría presentada; sólo se usa Bombillo LED suministrado).
- Seguro del lente tipo abrazadera en acero inoxidable.
- Lente y abrazadera asegurados con guaya para prevenir caídas y rupturas del lente.
- Diseñado de acuerdo a OACI y FAA.

BENEFICIOS

- Largo tiempo de vida gracias a su lente de vidrio que no se degrada con la intemperie, a su acabado con pintura electrostática y al seguro tipo abrazadera de acero inoxidable.
- Fácil acceso gracias a su seguro tipo abrazadera, se puede cambiar la lámpara sin utilizar herramienta.
- Bajo consumo de energía y larga duración (se suministra con bombillo LED 9.5W)
- Diseñada bajo normatividad aeronáutica.
- Puede funcionar con unidades de control fotoeléctrico e intermitentes.



CUMPLIMIENTOS

- Cumple como luz de obstrucción tipo L-810 Según FAA (con la referencia de bombillo suministrado).
- Cumple como luz de baja intensidad tipo B Según OACI (con la referencia de bombillo suministrado).

MATERIALES

- Cuerpo en aluminio de bajo contenido de cobre.
- Lente de vidrio de fresnel rojo omnidireccional.
- Abrazadera de acero inoxidable.
- Empaque en caucho.
- Acabado en pintura amarilla electrostática.

Luminaria para Pistas LA-1 iluram

RANGO ELÉCTRICO

- Acepta bombillos hasta 20W, (Para luces de aeronavegación y para la fotometría presentada; sólo se usa Bombillo LED suministrado).

OPCIONES DE PRODUCTO

- La conexión puede ser roscada NPT 1"
- Puede venir en unidad doble (back up).
- El color del lente se puede suministrar en transparente, verde, azul o amarillo.

GARANTÍA

- Un año por defectos de fábrica.

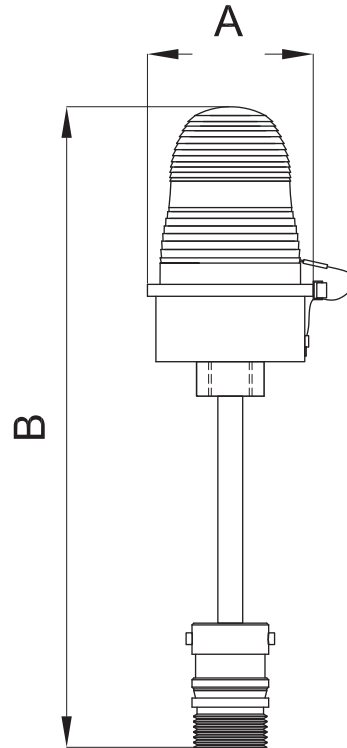

Referencia	Voltaje (VAC)	Vataje (W)	Intensidad	Acceso	Dimensiones (mm)		Tipo Bombillo
					A	B	
LA-1	120	10	Baja	3/4 Npt	119	385	LED 9.5 W

Fotometría

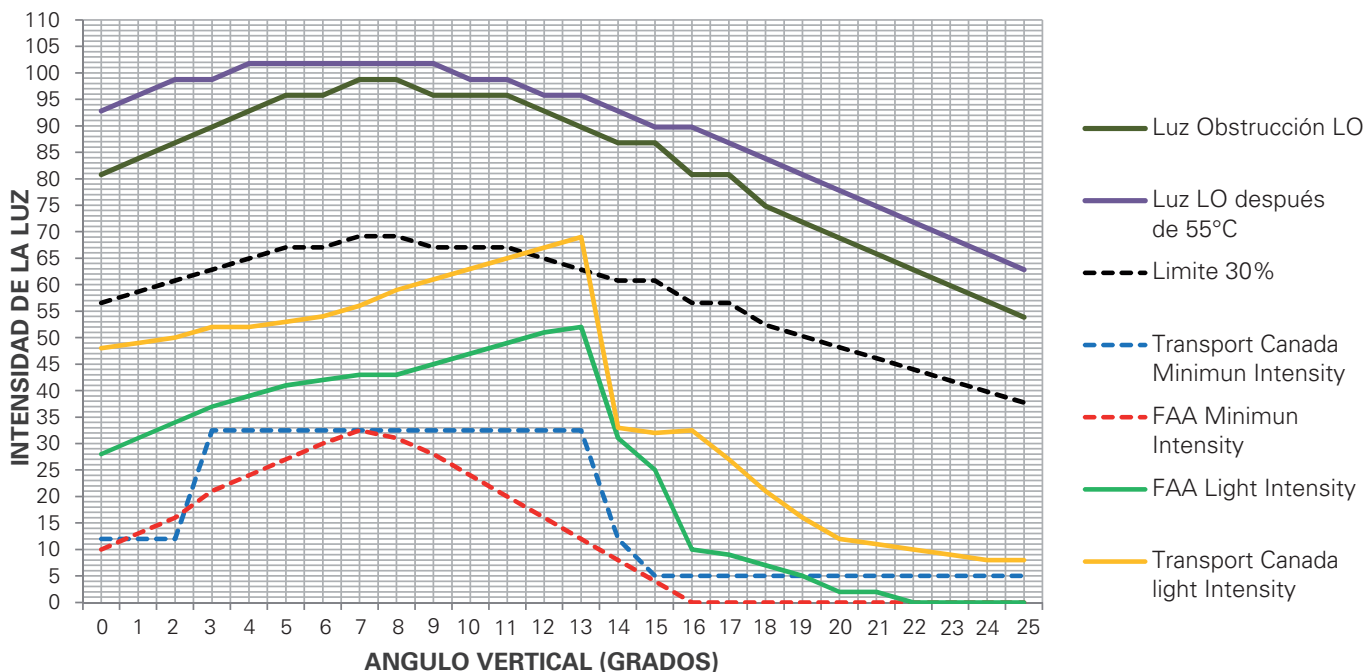

Faro de Empotrar LO-H2 iluram

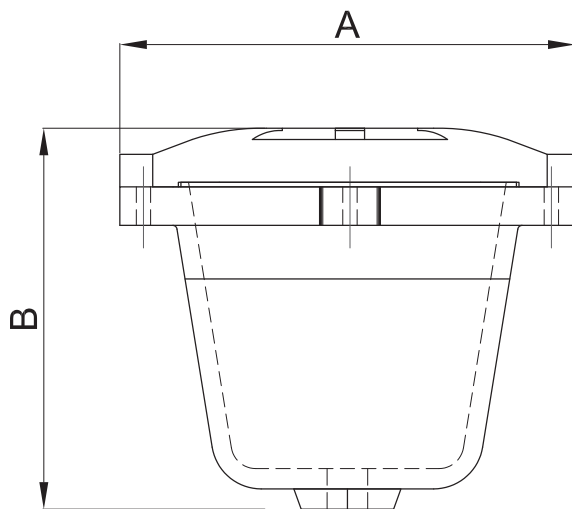
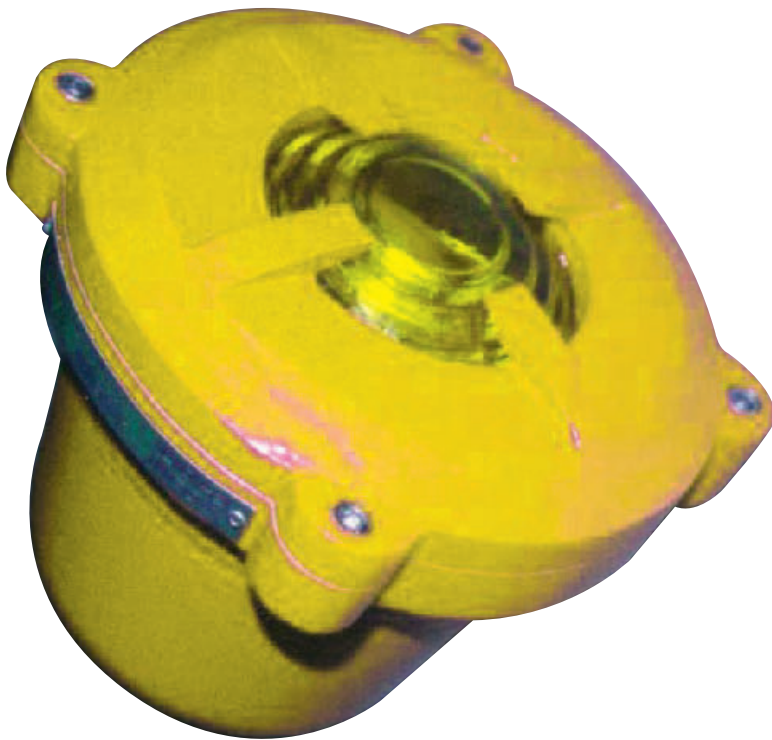

Referencia	Vataje (W)	Tipo
LO-H2L	3	LED
LO-H2L	50	Halógeno

APLICACIONES

Diseñado para ser empotrados en pista de helipuertos y señalar en forma vertical omnidireccional para ser observados desde gran altura.

Para ser instalado en el área de aterrizaje, sin que sea un obstáculo para la aeronave, permitiendo el flujo de personal.

CARACTERÍSTICAS

- Protección contra la intemperie NEMA 4 y 4X (IP 65).
- Cuerpo en fundición de aluminio de bajo contenido de cobre.
- Lente en vidrio de color resistente al choque térmico y protegido contra la intemperie.
- Rejilla protectora.
- Acabado en pintura de poliéster electrostática amarilla.
- Con sistema de desagüe para evitar represamiento de agua dentro de su cavidad.

MATERIALES

- Cuerpo en aluminio de bajo contenido de cobre.
- Acabado en pintura amarilla electrostática.
- Fuente luminosa LED, opcional halógena.

RANGO ELÉCTRICO

- Acepta bombillos LED de 3W y halógenos hasta 50W

OPCIONES DE PRODUCTO

Colores:

- Amarillo en zona perimetral de delimitación de la pista de Helipuerto.
- Verde en el eje central del interior de la pista para aproximación y partida.
- Azul puede ser utilizada en el umbral de aproximación a la pista.

GARANTÍA

- 1 Año por defectos de fábrica.

Reflector superficial para Helipuerto LOR

APLICACIONES

Diseñado específicamente para iluminar la plataforma de helipuertos, facilitando las maniobras nocturnas de descenso o con poca visibilidad del helipuerto.

CARACTERÍSTICAS

- Protección contra la intemperie NEMA 4X. (IP 65).
- Cuerpo en fundición de aluminio de bajo contenido de cobre.
- Acabado en pintura electrostática amarilla para permitir su visibilidad aún durante el día.
- Visera antirreflexiva cuyo fin es el de no afectar la visión del piloto.
- Conexión NPT 1/2" (estándar).
- Sello con empaque de alta resistencia térmica que lo hace hermético al agua.
- Bombillo(s) incluido(s)
- Lentes y empaque reemplazables en campo
- Dimensiones reducidas para un mejor manejo e instalación.
- Utiliza uno o dos bombillos fluorescentes compactos tipo PAR-38 y una visera que impide el deslumbramiento al piloto y con la opción de incluir una luz de tipo perimetral en la parte superior de la unidad.

MATERIALES

- Cuerpo en aluminio de bajo contenido de cobre.
- Acabado en pintura amarilla electrostática.
- Fuente luminosa halógena.

RANGO ELÉCTRICO

- Acepta bombillos hasta 50W

OPCIONES DE PRODUCTO

- Con opción de uno o dos reflectores de luz halógena de 50W cada una.
- Pueden contener luz perimetral amarilla en su parte superior.

GARANTÍA

- 1 Año por defectos de fábrica.

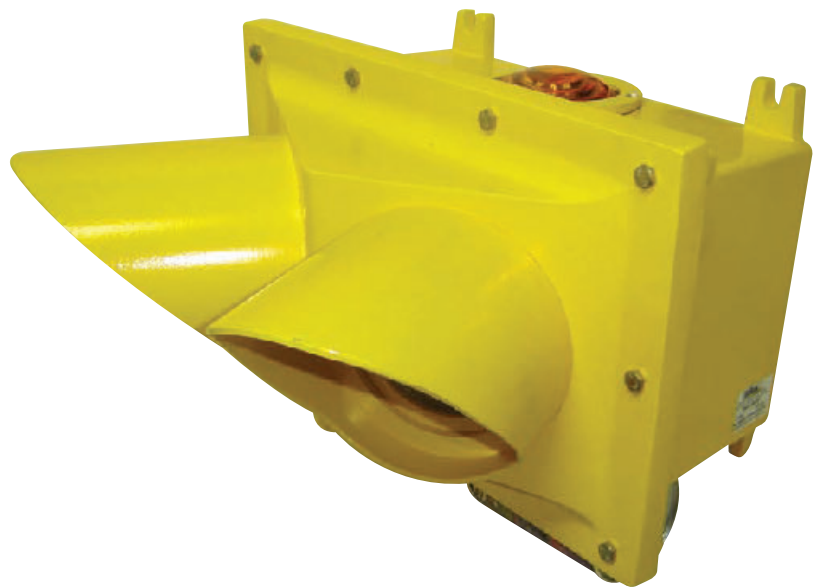

Referencia	Reflector	Potencia (W)	Tipo Luz	Potencia Perimetral	Tipo Bombillo	Dimensiones (mm)		
						A	B	C
LO-R1	1	23	Fluorescente	50	Halógeno	266	313	360
LO-R1P	1 y luz perimetral	23						
LO-R2	2	23		406	269	370		
LO-R2P	2 y luz perimetral	23		50				

